



P: 866.733.0233
www.solerpalaucanada.com



MODEL TDB (Sizes 18-60) BELT DRIVE TUBAXIAL DUCT FANS

STANDARD FEATURES

- Heavy-gauge rolled steel construction.
- Integral inlet and outlet flanges with mounting holes.
- Continuous welded and epoxy coated.
- Belt and bearing tube.
- Removable bearing cover for ease of maintenance.
- Eight mounting supports welded to each fan.
- Adjustable motor base for belt tensioning.
- Extended lube lines.
- Aluminum airfoil propeller.
- Sized for minimum 150% of drive horsepower.
- Bearings are designed for minimum 200,000 hour life, L50.
- Cast iron self-aligning pillow block ball bearings.
- Bearings are sealed and prelubricated.
- AMCA Air and Sound Certified
- cULus 705 Listed

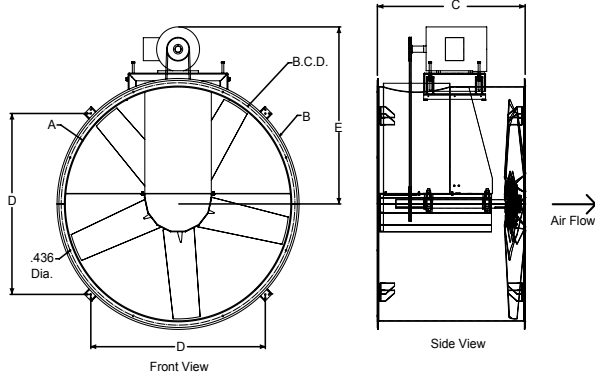

Model No.	Housings				B.C.D.	E (Max)	Holes		Max Motor Frame	Steel Housing Gauges	Avg. Ship Wt. (Lbs)
	I.D. A	O.D. B	Length C	D			Dia.	#			
18	18-3/8	22-1/2	22*	17-15/16	19-3/4	25-1/2	7/16"	8	182T	14	140
20	20-3/8	24-1/2	22	18-3/8	21-3/4	26-1/2	7/16"	8	184T	14	150
24	24-3/8	28-9/16	23	21-1/4	25-3/4	28-1/2	7/16"	8	184T	12	220
30	30-3/8	34-9/16	24	25-1/2	32	35	7/16"	8	254T	12	260
34	34-3/8	38-9/16	27	28-5/8	36-3/8	37	7/16"	8	254T	12	310
36	36-3/8	40-5/8	29	29-13/16	38	38	7/16"	8	254T	10	410
42	42-1/2	47	30	34-1/8	44-1/4	42	7/16"	8	254T	10	480
48	48-1/2	53	33	38-3/8	50-3/4	45	7/16"	8	284T	10	600
54	55	59-1/2	38	43	57-1/4	48	7/16"	8	284T	10	730
60	61	65-1/2	40	47-1/4	63-1/4	54-1/2	7/16"	8	286T	10	798

*Motor may extend past unit

NOTE: All dimensions shown are in inches.

FAN SPECIFICATIONS									MOTOR SPECIFICATIONS				
Line	Qty.	Model No.	Tag	CFM	SP	Fan RPM	BHP	Sones	HP	Volts	Phase	Hertz	Encl
1													
2													
3													
4													
5													

ACCESSORY ITEMS					ACCESSORY ITEMS						
	1	2	3	4	5		1	2	3	4	5
<input type="checkbox"/>						<input type="checkbox"/>					
<input type="checkbox"/>						<input type="checkbox"/>					
<input type="checkbox"/>						<input type="checkbox"/>					
<input type="checkbox"/>						<input type="checkbox"/>					
<input type="checkbox"/>						<input type="checkbox"/>					

Subject to change unless approved in submittal by S&P.
TDB18-60_Submittal

